

EB12-250

12V250Ah / 10hr rate



Introduction

Generagy EB series is designed for European standard with 12-year design life in float service. The series battery is featured of high consistency, excellent performance and reliable standby service life. It is widely applied in float service, UPS/EPS, medical equipment, telecom, photovoltaic, control system and security system.

Battery Features

- Increase durability and deep cycle ability for heavy demand applications
- Low self-discharge
- Fully tank formed plates
- Low impurity electrolyte
- Spill proof / leak proof
- Multi-position usage
- ABS case and cover VO upon request
- Very high purity lead

Electrical Specification

Design floating Life @ 20°C (68°F)	12 years
Nominal Capacity @ 20°C (68°F)	
20 hour rate 13.18A to 1.75Vp	263Ah
10 hour rate 25.04A to 1.80Vpc	250 Ah
Internal Resistance	
(Fully charged battery @ 20°C (68°F))	3mΩ
Max. Discharge Current @ 20°C (68°F)	2500 A (5S)
Charge Methods: Constant voltage charge @ 20°C (68°F)	
Cycle Use	14.7 ~ 14.9V
Max. Current	66 A
Standby Use	13.6 - 13.8V
Operating Temperature Range	-30 ~ 50°C
<i>Notes: battery voltage must be adjusted according to temperature. Please refer to our recommendation.</i>	
Self-Discharge	<3% of capacity declined per month @ 20°C (68°F).

Battery Picture & Terminal Layout

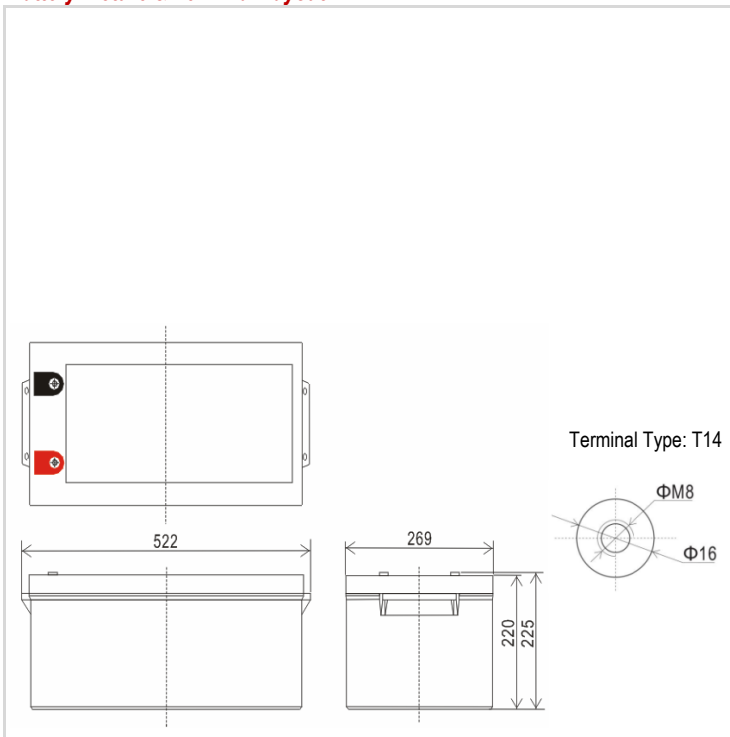

Dimension & Weight

	Dimension (± 2mm)				Weight (± 2%)
	Length	Width	Height	Total Height	
	522 mm	269 mm	220 mm	225 mm	70.5 kg
	20.6 inch	10.6 inch	8.7 inch	8.9 inch	155.4 lbs

Typical Applications

- UPS & EPS Telecommunications Power Utility Security Power Supply

Certificates



Constant Current Discharge (Amperes @ 20°C (68°F))

V/cell	10min	15min	20min	25min	30min	35min	40min	45min	50min	55min	1hr	2hr	3hr	4hr	5hr	10hr	20hr
1.60	505.99	386.25	333.67	281.10	237.93	240.72	224.47	209.61	195.99	184.20	188.19	102.03	72.60	60.29	49.29	26.34	13.30
1.65	480.47	366.77	318.56	270.35	231.55	234.35	218.90	204.81	192.00	181.01	185.63	100.05	71.20	59.03	48.16	26.21	13.30
1.70	460.63	351.63	305.99	260.35	224.11	226.59	211.75	198.22	186.02	175.64	180.52	96.68	69.56	57.64	47.02	25.96	13.30
1.75	439.37	335.40	292.33	249.27	215.60	218.03	204.19	191.62	180.43	171.07	176.69	94.00	68.05	56.37	46.01	25.71	13.18
1.80	416.69	318.09	277.96	237.83	207.10	209.27	196.24	184.43	174.05	165.50	171.58	90.62	66.40	54.98	44.87	25.04	13.05

Constant Power Discharge (Watts/cell @ 20°C (68°F))

V/cell	10min	15min	20min	25min	30min	35min	40min	45min	50min	55min	1hr	2hr	3hr	4hr	5hr	10hr	20hr
1.60	878.7	670.80	590.33	509.87	444.45	450.81	418.77	389.31	361.92	338.79	343.09	188.60	137.25	113.88	93.79	52.55	27.72
1.65	847.6	646.99	570.57	494.14	432.76	438.87	408.04	379.72	353.54	331.62	336.71	184.78	135.99	112.62	92.52	52.05	27.72
1.70	814.96	622.11	549.37	476.64	418.95	424.94	395.71	368.92	344.36	324.06	330.32	180.32	133.46	110.66	91.13	51.03	27.35
1.75	779.53	595.06	526.38	457.70	404.06	409.81	382.19	356.93	333.99	315.31	322.65	174.59	129.67	107.94	89.49	50.65	26.85
1.80	741.26	565.85	501.59	437.33	388.12	393.50	367.48	343.75	322.43	305.36	313.70	168.41	126.25	105.23	87.47	50.15	26.61

Subject to revision without notice. Please contact our sales representatives for latest version.

Web: www.generagybattery.com | Email: sales@generagybattery.com

EB12-250

12V250Ah / 10hr rate



Graphs

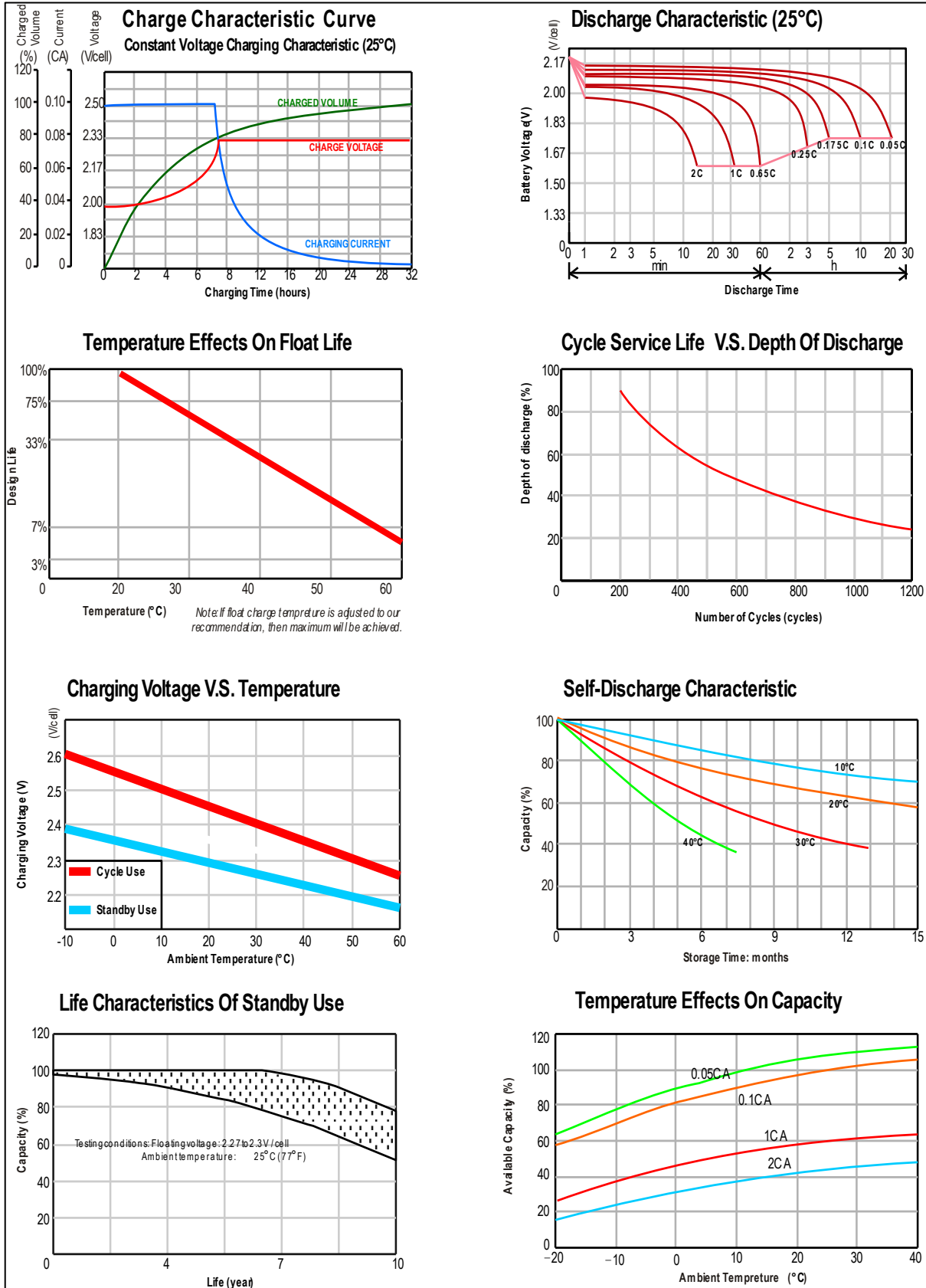

Subject to revision without notice. Please contact our sales representatives for latest version.